



**NATIONAL PIPE & PLASTICS, INC.**

American-made products since 1970

Corporate Offices  
3421 Old Vestal Road, Vestal, NY 13850  
800.836.4350 607.729.9381 Fax: 607.729.6130  
www.nationalpipe.com

**ASTM D3034 and ASTM F-679 Gravity Sewer Pipe**  
**Standard Perforation**  
**For Underdrain Systems**

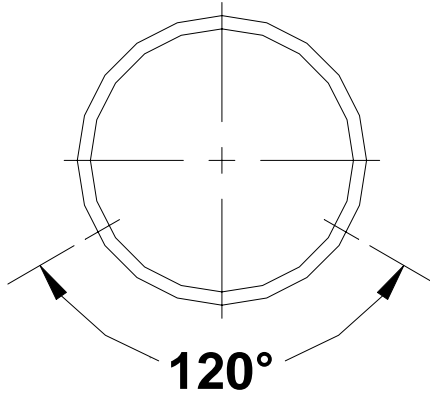

**Nominal Pipe Size**

**Perforation Arrangement**

4" - 6"	Hole Size: 1/2" +/- 1/16" Center-to-Center: 5" +/- 1/4" Rows of Holes: 2, 120° +/- 5° Perforations as per ASTM Standard D2729
8" - 15"	Hole Size: 7/8" +/- 1/16" Center-to-Center: 6" +/- 1/4" Rows of Holes: 2, @ 120° +/- 5° Perforations as per National Standard NP714
18" - 24"	Special perforation upon request. Hole pattern and size must be specified.

Note: **NATIONAL** ASTM D-3034 and ASTM F-679 Gravity Sewer Pipe is manufactured from a PVC compound with a cell class 12454-B, as defined in ASTM D-1784, and meets the standard specifications of ASTM D-3212, if integral gasketed joints are provided. Gasket material conforms to the requirement of ASTM F-477.  
Standard pipe length : 14'

Other hole sizes and perforation patterns are available on request.