



NATIONAL PIPE & PLASTICS, INC.

American-made products since 1970

Corporate Offices
3421 Old Vestal Road, Vestal, NY 13850
800.836.4350 607.729.9381 Fax: 607.729.6130
www.nationalpipe.com

ASTM D3034 Gravity Sewer Pipe Perforated To
ASTM F-758
Highway/Airport Underdrainage Systems

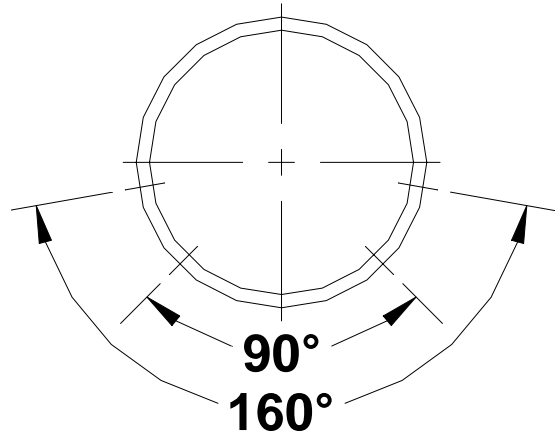

<u>Nominal Pipe Size</u>	<u>Perforation Arrangement</u>
4"	Hole Size: 3/8" Center-to-Center: 3-1/4" +/- 1/4" Rows of Holes: 2, 90° +/- 3°
6"	Hole Size: 3/8" Center-to-Center: 3-1/4" +/- 1/4" Rows of Holes: 4, 2 @ 90°, 2 @ 160° +/- 3°
8"	Hole Size: 3/8" Center-to-Center: 3-1/4" +/- 1/4" Rows of Holes: 4, 2 @ 90°, 2 @ 160° +/- 3°

Note: **NATIONAL** ASTM D-3034 Gravity Sewer Pipe is manufactured from a PVC compound with a cell class 12454-B, as defined in ASTM D-1784, and meets the standard specifications of ASTM D-3212, if integral gasketed joints are provided. Gasket material conforms to the requirement of ASTM F-477.

Standard pipe length: 14'